



Masport Inlet Filter

Masport's Inlet Filter is designed as a protective measure to be installed between the scrubber/ secondary and the pump on the inlet side. By capturing particles that could damage the vacuum/ pressure pump, the inlet filter extends your system's life and performance. Each inlet filter is equipped with durable iron wing nuts which allow the lid to be removed quickly and easily. The unique design features a 300 micron washable stainless steel element. An inlet filter is a must in any system to prevent contamination of the vacuum pump by foreign particles. The inlet filter comes in 1 1/2", 2 1/2", and 3" N.P.T. sizes.

The Inlet Filter can be mounted vertically or horizontally without losing effectiveness; although horizontal mounting is recommended to prevent debris from falling into the pump during filter cleaning.



Inlet Filter with lid removed



300 Micron Washable Stainless Steel Filter

SPECIFICATIONS

ASSEMBLY NUMBER	15115	15116	15118	15120
Porting Size	1 1/2" N.P.T.	2 1/2" N.P.T.	3" N.P.T.	3" B.S.P.
Filter Element	300 micron	300 micron	300 micron	300 micron
Net Weight - lbs.	23	30	32	32

OPERATIONAL DATA

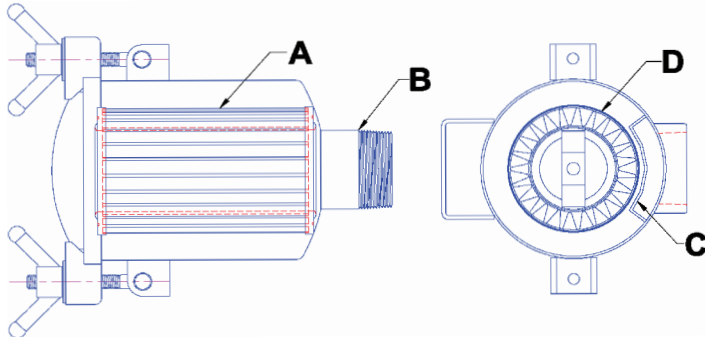

All Inlet Filter Models

- A. Filter Element**
 - 50 mesh for superior protection
 - 300 micron pleated cleanable stainless steel for ease of maintenance
- B. Portings**
 - 1 1/2", 2 1/2", and 3" N.P.T. or 3" B.S.P. to match a variety of pumps.
- C. Air Deflector**
 - 12 gauge hot rolled steel for ruggedness and durability.
- D. Silicone Endcaps**
 - Heat and chemical resistant

Replacement Filter Elements:

26108	1 1/2" Filter Element
26113	2 1/2" Filter Element
26113	3" Filter Element



DIMENSIONAL DATA

- A - FEMALE N.P.T.
- B - MALE N.P.T.

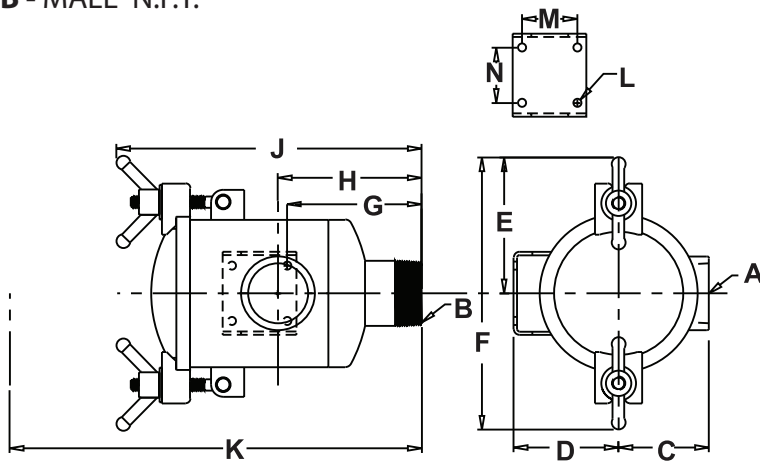

K* - Allowance for Filter Removal

Assembly Numbers

	15115	15116	15118	15120
A	1 1/2"	2 1/2"	3" NPT	3" BSP
B	1 1/2"	2 1/2"	3" NPT	3" BSP
C	4 3/4"	5 3/32"	4 7/8"	4 7/8"
D	5 11/16"	5 11/16"	5 11/16"	5 11/16"
E	7 3/8"	7 3/8"	7 3/8"	7 3/8"
F	14 3/4"	14 3/4"	14 3/4"	14 3/4"
G	4 1/16"	6 9/16"	7 5/16"	7 5/16"
H	5 7/16"	7 1/16"	7 13/16"	7 13/16"
J	12 9/16"	15 13/16"	16 9/16"	16 9/16"
K*	13 1/2"	21"	22"	22"
L	7/16"	7/16"	7/16"	7/16"
M	3"	3"	3"	3"
N	3"	3"	3"	3"

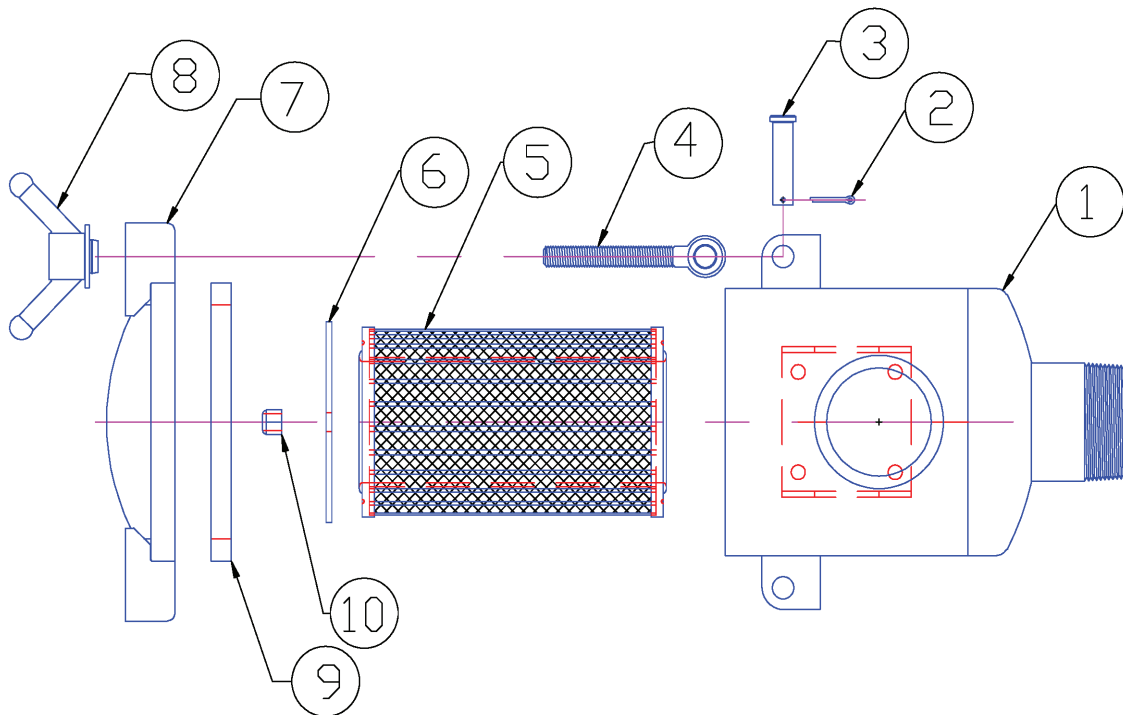

Parts List

Ref	Description
1	Body Inlet Filter
2	Pin Cotter 1/8" x 1"
3	Pin Eye Bolt Hinge
4	Bolt Eye Manway
5	Filter Element Stainless
6	Plate Retainer Filter
7	Lid Inlet Filter
8	Nut Wing 5/8"
9	Gasket Nitrile 7" I.D.
10	Nut 1/2" Nylon Insert

Inlet Filter

15115	15116	15118	15120
Part #	Part #	Part #	Part #
18118	18130	18119	18108
32605	32605	32605	32605
32602	32602	32602	32602
32603	32603	32603	32603
26108	26108	26108	26108
29226	29226	29226	29226
18117	18117	18117	18117
32606	32606	32606	32606
36516	36516	36516	36516
32008	32008	32008	32008